

Smart Thermostat Wireless

RDS110.R





To control heating applications in apartments, single family homes, dormitories, and other residential as well as commercial spaces.

- Backlit, 90 mm color LCD touch screen for intuitive local operation
- Mobile app for smart phones
- Patented¹⁾ self-learning algorithm with PID response
- Green leaf for energy-optimized operation
- Operates automatically following a schedule
- Presence detection via geo-fencing
- Multifunctional inputs for remote sensors
- Communicates with in-house devices via Thread
- Integration into any BACnet system
- Satisfies Class IV according to the Eco design directive

1) Patent pending

Room thermostat features

- Direct temperature and operating mode selection
- RoomOptiControl¹⁾ function with Green leaf indication for energy-optimized operation
- Temperature setting limitation for use in public spaces
- Air quality indication: “Good” , “Okay” , “Poor” 
- Screen lock protection against unauthorized access
- Manual switchover between “At home”, “Away” and “Off” on touch screen
- Room temperature detection and control using the built-in temperature sensor or an optional remote sensor
- Optional temperature averaging using an additional remote temperature sensor
- Patented self-learning algorithm with PID response (patent pending) guaranteeing optimum temperature control performance in all room types
- Optimum start control function that advances the switch-on time to ensure the selected setpoint is reached as required
- Floor temperature limitation using a remote, wired sensor in electric floor-heating applications
- Humidity control using the built-in humidity sensor or an optional remote sensor
- Two multifunctional inputs, optional and configurable for remote sensors (see section Use [▶ 3] for more information)
- Periodic pump/valve operation to protect against seizing
- Navigation wizard for guided, fast commissioning
- Wireless communication with receiver RCR114.1 and radiator valve SSA911.01TH through Thread
- Local modification of BACnet settings (see the User Guide [A6V11562455] for more information)
- Remote firmware upgrade capability

1) Automatically detect unnecessary energy consumption in the room and display it using Green Leaf on the thermostat. When the leaf is red, the thermostat setting has been changed. Touch the red leaf to return the setting to energy-optimized operation. See the User Guide (A6V11562455) for more information on this function.

Remote operation and monitoring

- Mobile app for smartphones based on iOS and Android operating systems
- Support “Dark” and “Light” background colors on mobile app
- Manual switchover between “At home”, “Away” and “Off” operating modes on the mobile app
- Presence detection using geo-fencing for energy-efficient operation
- Individual schedule for each day of the week can be programmed using the mobile app with the following operating modes (maximum 8 modes per day)
 - “Comfort”: To enjoy comfort and coziness when you are at home.
 - “Economy”: To save energy when maximum comfort is not required, for example, in the evening or at night.
 - “Unoccupied”: To save energy costs by reducing the temperature setpoint, for example, when the room is unoccupied.
- Individual schedule for domestic hot water boiler
- User account management
- Monitoring of actual and historical temperature and humidity values
- Secure access and data transmission with the Siemens Cloud Computing Platform

The RDS110.R is designed to control heating applications in apartments, single family homes, dormitories, and other residential and commercial spaces.

The RDS110.R controls the following plant components with its peripherals:

RDS110.R with radiator valve actuator (SSA911.01TH):

- Radiator with valve (SSA911.01TH)

NOTE: The RDS110.R can control a maximum of 6 valve actuators in parallel, with the same control settings.

RDS110.R with wireless receiver (RCR114.1):

- Gas boiler
- Radiator with pump
- Electric floor heating
- Fan with electric heating
- Floor heating with valve
- Floor heating with pump
- Electric radiator
- Electric boiler
- Generic heating device

	NOTICE
	When selecting the gas boiler application, ensure a hydronic heating is used. The RDS110.R is not calibrated for use in combination with a gas-fired ducted heating system.

The RDS110.R can control a maximum of 6 receivers in parallel, with the same control settings.

The RCR114.1 has two relay outputs, one of which is for heating equipment (listed above). The other relay is available to optionally control a domestic hot water (DHW) boiler, humidifier or dehumidifier.

The RDS110.R has two multifunctional inputs, optional and configurable for:

- Operating mode switchover contact
 - The thermostat switches to the “OFF” mode if the input has been configured as Normally Open. Useful for a room or key card.
- Remote room temperature sensor
 - The remote temperature sensor can acquire the current room temperature. If the sensor input signal is lost, the thermostat controls the room according to the internal sensor.
- Floor temperature sensor
 - The floor heating limitation function prevents the floor temperature from exceeding a preset value.
- Outside air temperature sensor
 - The outside air temperature sensor can acquire outside air temperature information for display on the touch screen.
- Remote humidity sensor
 - The thermostat can control a standalone humidifier or dehumidifier. The relative humidity is measured by the remote humidity sensor or internal humidity sensor.
- VOC and CO₂ sensors
- Condensation monitor
- Universal contact. A notification shows up in the mobile application when the input status switches to “Normally closed” (the circuit is closed).

- Presence detector. The thermostat switches from “Unoccupied” to “Comfort” if the detector detects someone in the room. It remains in “Unoccupied” for a maximum of one hour after the last presence detection.

!	NOTICE
	See the User guide (doc ID: A6V11562455) for more information about input configurations.

Topology

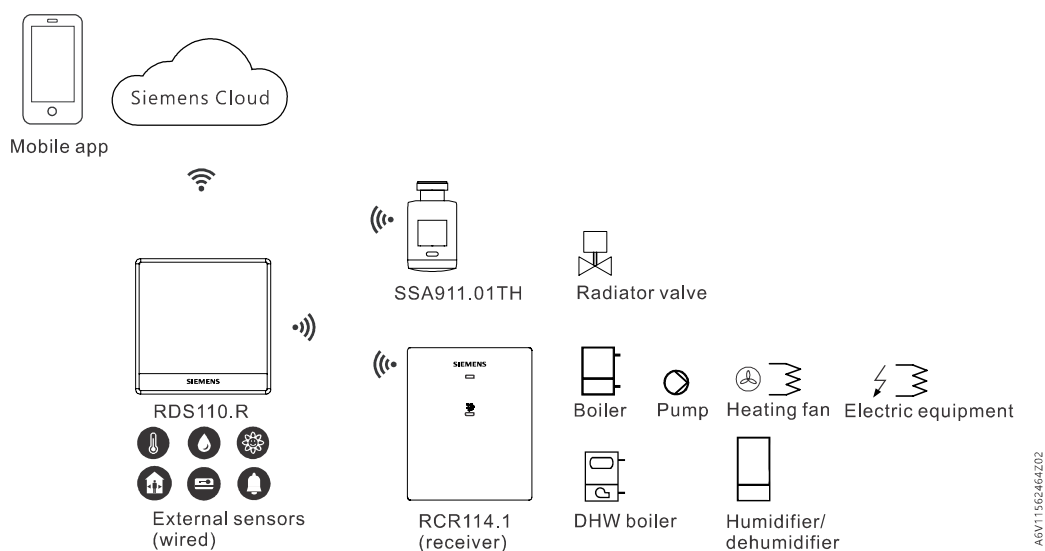

NOTES:

1. Install the receiver close to the RDS110.R if possible. The communication range in a building is typically 60 m, without any blockages. Note that range can vary, because walls, floors, wireless interference and other factors may reduce the signal strength.
2. Add a repeater (RCR114.1) if the connection fails due to low signal strength (distance or blockagers [walls, and so on]).
3. The thermostat can only connect to one heating system. It cannot simultaneously control the wireless relay and the valve actuator.
4. The thermostat can control up to six wireless relays or valve actuators.

Mechanical design

The room thermostat consists of the following parts:

- Housing front with touch screen
- Housing rear with terminals and temperature sensor
- Metallic mounting plate for wall mounting
- Accessories

Operation and settings

Normal display



1	Tap to display detailed information and additional settings.
2	Tap to display additional measurements, for example, outside air temperature. (Only if external sensor is connected)
3	Tap to display notifications (only visible if applicable)
4	Room temperature
5	Tap to toggle between “At home” and “AWAY”.
6	<p>Displays whether the thermostat is following a schedule (AUTO) or your setpoint changes permanently (🔥). Following a schedule can mean the following:</p> <ul style="list-style-type: none"> • If you are connected to a network and you have set your schedule, the thermostat follows your schedule. Your temporary change of the temperature setpoint only takes effect during the currently scheduled mode. • If you are connected to a network but no schedule is set, the thermostat applies the system’s default schedule. For more information about default schedules, see <i>Time-based schedules</i>. • Without network connection or valid time, the thermostat cannot retrieve schedule information from the Cloud. It only works under the “Comfort” mode.
7	<p>Tap or slide to change the room temperature setpoint. *</p> <p>🔥 The thermostat is in heating mode – at some point, the relay will be energized, depending on the heating demand and application type.</p> <p>📉 The thermostat is not in heating mode.</p>

NOTICE! * There is a few seconds’ delay between the color change in the temperature bar and the reaction of the relays.



NOTICE

After initial setup of the thermostat, the displayed room temperature may not be correct because the temperature sensors need time for calibration. Wait for at least one hour for the thermostat to calibrate.

Idle display





The RDS110.R screen switches to **idle** mode after 2 minutes of inactivity. The **idle** screen of the RDS110.R can be displayed as a simple screen with basic room values, or as a blank, black screen. The simple screen is the default setting.



1	Relative room humidity
2	Room air quality status: good 🌿, average 🌿, poor 🌿. (Displayed only if an external air quality sensor is connected to the thermostat)
3	Outside air temperature (displayed only if an external temperature sensor is connected to the thermostat)
4	Green leaf: Energy-optimized mode. Red leaf: Tap to restore the energy-optimized mode.
5	Room temperature

NOTE: The icons displayed in **idle** mode may differ if you've connected external sensors to your thermostat. For example, the idle screen may display room air quality status or outside air temperature if a related external sensor is connected to the thermostat. However, the relative room humidity value and green leaf indication are always displayed on the idle screen.

To set idle display

- On the Home screen, tap , then tap > until the "Settings" page displays.
- Tap  > , and then tap  or  to set the idle screen as pure blank or with values.

Type summary

Product number	Stock number	Description
RDS110.R	S55772-T103	Smart Thermostat Wireless

Ordering

- When ordering, indicate product number, stock number and description.
- Order valve actuators separately.

Inbox items

Items	Quantity
Thermostat (front and rear)	1
Metallic mounting plate	1
Set of screws and plastic insert	1
Quick guide	1
Mounting instructions	1
Activation code sticker	1
Wiring sticker	1

Equipment combinations

Receiver

Type of unit	Product number	Stock number	Datasheet*
Smart Thermostat Receiver	RCR114.1	S55772-T104	A6V11562464

Actuator

Type of unit	Product number	Stock number	Datasheet*
Radiator valve act. THREAD	SSA911.01TH	S55181-A101	A6V11739247

Remote sensors

Type of unit	Product no.	LG-Ni1000 at 0 °C	Pt1000 at 0 °C	NTC 10k at 25 °C	DC 0...10 V	Datasheet*
Room temperature sensors						
- Wall-mounted	QAA24	x				CM1N1721
	QAA2012		x			CE1N1745
	QAA2030			x		CE1N1745

Type of unit	Product no.	LG-Ni1000 at 0 °C	Pt1000 at 0 °C	NTC 10k at 25 °C	DC 0...10 V	Datasheet*
	QAA2061				x	CE1N1749
	QAA2061D ²⁾				x	CE1N1749
- Flush-mounted ¹⁾	AQR2531AN W	x				CE1N1408
	AQR2532NN W				x	CE1N1411
- Concealed	QAA64 (vandal-proof)	x				CM1N1722
Outdoor temperature sensors						
	QAC22	x				CE1N1811
	QAC2012		x			CE1N1811
	QAC2030			x		CE1N1811
	QAC3161				x	CE1N1814
Cable temperature sensors						
	QAP21.3	x				CE1N1832
	QAP22	x				CE1N1831
	QAP21.3/8000	x				CE1N1832
	QAP2012.150		x			CE1N1831
	QAP1030.200			x		CE1N1831
Room humidity sensors						
- Wall-mounted	QFA2000	Owing when mountin gunit			x	CE1N1857
- Wall-mounted including temperature	QFA2020	x (T)			x (r.h.)	CE1N1857
	QFA2060				x (T+r.h.)	CE1N1857
	QFA2060D ²⁾				x (T+r.h.)	CE1N1857
- Flush-mounted ¹⁾ including temperature	AQR2534AN W + AQR2540Nx	x (T)			x (r.h.)	CE1N1410
	AQR2535NN W + AQR2540Nx				x (T+r.h.)	CE1N1410
Indoor air quality sensors						

Type of unit	Product no.	LG-Ni1000 at 0 °C	Pt1000 at 0 °C	NTC 10k at 25 °C	DC 0...10 V	Datasheet*
- CO ₂	QPA2000				x	149-910
- VOC + CO ₂	QPA2002				x	149-910
	QPA2002D ¹⁾				x	149-910
- CO ₂ including temperature	QPA2060				x(CO ₂ +T)	149-910
	QPA2060D ¹⁾				x(CO ₂ +T)	149-910
- Duct-mount CO ₂	QPM2100				x	149-909
- Duct-mount VOC + CO ₂	QPM2102				x	149-909
- Duct-mount CO ₂ including temperature	QPM2160				x(CO ₂ +T)	149-909
- VOC	QPA1000				x	CE1N1961
Condensation monitors						
- Condensation monitor	QXA2100					A6V10741072
- Condensation monitor with offset sensor	QXA2101					A6V10741072

* The documents can be downloaded from <http://siemens.com/bt/download> by specifying the product number as shown in the above table.

1) Requires a mounting plate and/or design frames.

2) With digital display.

Accessories (Optional)

Type of unit		Product no.	Datasheet*
White decorative frame and metallic mounting plate for installation on rectangular conduit box (1 set)		ARG100.01 S55772-T102	A6V11190640

NOTE: Accessories are not included with the unit and should be ordered separately.

* The documents can be downloaded from <http://siemens.com/bt/download> by specifying the product number as shown in the above table.

Topic	Title	Document ID
Mounting and installation	RDS110.R Mounting instruction	A6V11562441
Installation and operation	RDS110.R User guide	A6V11562455
Startup wizard	RDS110.R Quick guide	A6V11562445
CE declaration		A6V11802452
Product environmental declaration		A6V11806767

Related documents such as environmental declarations, CE declarations etc., can be downloaded from <http://siemens.com/bt/download>.

Notes

Security

	<p>⚠ CAUTION</p>
	<p>National safety regulations Failure to comply with national safety regulations may result in personal injury and property damage</p> <ul style="list-style-type: none"> • Observe any national provisions and comply with appropriate safety regulations.

Engineering

See the product documentation for information on engineering, selection and sizing connecting cables for supply voltage and field devices.

Installation

The mounting plate of the thermostat can be installed on CEE/VDE conduit boxes and on square boxes 75 x 75 mm. For installation on a rectangular conduit box (for example 105 x 72 mm), accessory ARG100.01 must be ordered, which includes a white decorative frame and a bigger mounting plate.

	<p>⚠ WARNING</p>
	<p>No internal line protection for supply lines to external consumers Risk of fire and injury due to short-circuits</p> <ul style="list-style-type: none"> • Adapt the line diameters as per local regulations to the rated value of the installed over-current protection device. • The AC 230 V mains supply line must have an external circuit breaker with a rated current of no more than 10 A. • Use only AC 230 V isolated wired cables, as the conduit box carries AC 230 V mains voltage. • Inputs X1-M-X2: Several switches may be connected in parallel. Consider the overall maximum contact sensing current of the switch rating. • Disconnect from power supply before removing the thermostat cover.

Commissioning

See the Quick guide and User guide (see Product Documentation) to configure your device. Commissioning includes the following:

- Internet connection
- Application setup
- Account registration and device pairing

NOTE:

Before configuring your thermostat, ensure that you are connected to the Internet, have a valid email address, and a smartphone.

Mounting

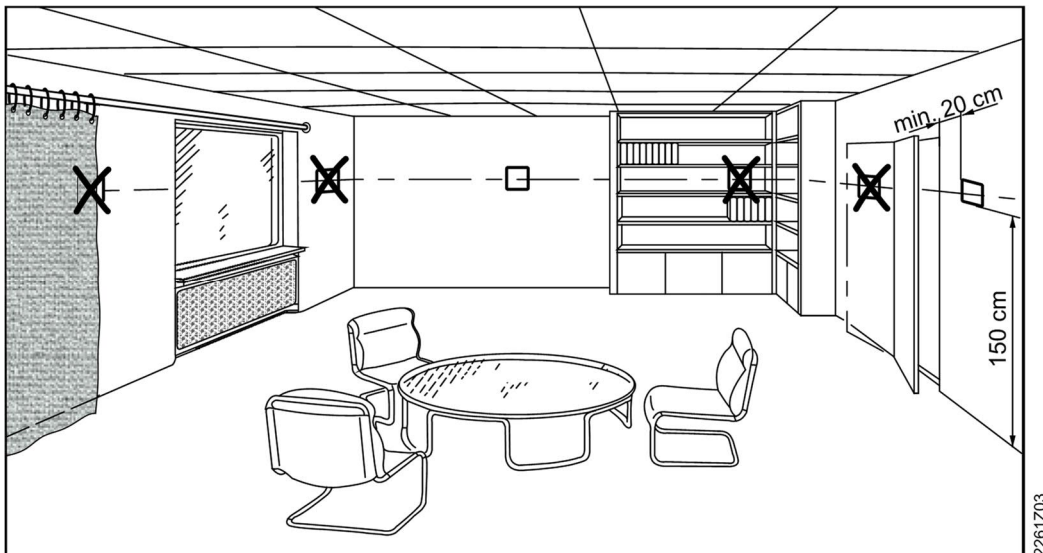

Note the following when mounting the unit:

- The devices are suitable for wall mounting.
- Recommended height: 1.50 m above the floor.
- Do not mount the devices in recesses, on shelves, behind curtains or doors, or above or near heat sources.
- Avoid direct sunlight.
- Seal the conduit box or the installation tube if any, as air currents can affect sensor readings.
- Observe to allowed ambient conditions.

Operation

End users can operate the thermostat directly on the touch screen, or download the mobile app “Siemens Smart Thermostat RDS” and perform operations on their smartphones, including:

- Creating and managing accounts
- Setting the operating mode (**Auto, away, home, manual**)
- Changing the room temperature (by setting new setpoints)
- Setting a weekly schedule (heating and domestic hot water)
- Opting for geo-fencing
- Selecting the Green leaf (switching to energy-optimized operation)
- Viewing temperature, humidity and heat demand trends

Supported smartphone types are as follows:

Operating system

OS	OS version	App store
iOS	iOS 12 or above	App store®
Android	Android™ 10.0 or above	Google Play™

Maintenance

The thermostat is designed for maintenance-free operation.

Disposal



The device is considered an electronic device for disposal in accordance with the European Guidelines and may not be disposed of as domestic garbage.

- Dispose of the device through channels provided for this purpose.
- Comply with all local and currently applicable laws and regulations.

Warranty

Technical data on specific applications are valid only together with Siemens products listed under "Equipment combinations". Siemens rejects any and all warranties in the event that third-party products are used.

Radio equipment directive

The equipment is using harmonized frequency in Europe and complies with the Radio Equipment Directive (2014/53/EU, formerly 1999/5/EC).

Power supply

Power supply	
Operating voltage	AC 230 V (+10% / -15%)
Frequency	48...63 Hz
Power consumption	Max. 9 VA
Standby power consumption (LCD off)	1.6 W
Maximum external supply line fusing	10 A circuit breaker

Radio parameters

Radio parameters	
Frequency band	2.4...2.4835 GHz
Maximum radio-frequency power	18 dBm
WLAN standard	IEEE 802.11b/g/n (HT20)
WLAN channel	1~13

Frequency band	2.4...2.4835 GHz
Maximum radio-frequency power	15 dBm
Thread standard	IEEE 802.15.4
Thread channel	11-26

Connections to multifunctional inputs X1 - M - X2	
Passive temperature sensors - Cable length max. (copper cable section) - NTC type Room temperature range Outdoor temperature range Floor temperature range* - Ni type Room temperature range Outdoor temperature range Floor temperature range* - Pt type Room temperature range Outdoor temperature range Floor temperature range*	90 m (1.5 mm ² wire), 70 m (1 mm ² wire) 60 m (0.75 mm ² wire), 40 m (0.5 mm ² wire) NTC10K at 25 °C 0...50 °C -50...80 °C -50...80 °C Ni1000 at 0 °C 0...50 °C -50...80 °C -50...80 °C Pt1000_375/Pt1000_385 at 0 °C 0...50 °C -50...80 °C -50...80 °C
Active DC 0 V ...10 V sensors - Room temperature range (default) - Outdoor temperature range (default) - Humidity range (default) - CO ₂ /VOC range (default) - Floor temperature range*	Min./max. configurable via parameters 0...50 °C -50...80 °C 0...100% 0...2000 ppm -50...80 °C
Digital contacts - Operating action - Contact sensing - Parallel connection - Input function	Selectable NO/NC DC 14...40 V, 8 mA (typ.) Maximum 20 thermostats per switch Selectable

* Available when electric heating is energized.

Operational data

Setpoint setting range
0...50 °C 12...35 °C (default)

Built-in room temperature sensor		
Temperature range	Accuracy at 25 °C	Display resolution
0...50 °C	±0.5 K	0.5 K

Built-in room humidity sensor		
Humidity range 0%...100%	Accuracy at 25 °C ±5% r.h.	Display resolution 1%

Connections

Interfaces	
Micro USB	A service port is limited to firmware upgrades and onsite diagnosis by professionals.

Wiring connections	
Screw terminal	Solid wires or prepared stranded wires: Maximum 1 × 0.5... 2.5 mm ² (14...20 AWG)

Conformity

Ambient conditions and protection classification	
Safety class as per EN60730	Class II
Degree of protection of housing as per EN 60529	IP30
Classification as per EN 60730	
Function of automatic control devices Operation altitude Degree of contamination Overvoltage category	Type 1 < 3000 m 2 III
Climatic ambient conditions	
Transport (packaged for transport) as per EN 60721-3-2 Storage as per EN 60721-3-1 Operation as per EN 60721-3-3	Transport/ Storage: Temperature -25...60 °C (-13... 158 °F) Air humidity 5...95% r.h. (non-condensing) Operation: Temperature 0...50 °C (23... 122 °F) Air humidity 5...95% r.h. (non-condensing)
Mechanical ambient conditions	
Transport as per EN 60721-3-2 Operation as per EN 60721-3-3	Class 2M2 Class 3M2

Standards, directives and approvals	
EU conformity (CE)	A6V11802452 ^{*)}
RCM conformity	A6V11231674 ^{*)}
Environmental compatibility	The product environmental declaration A6V11806767 ^{*)} contains data on environmentally compatible product design and assessments (RoHS compliance, materials composition, packaging, environmental benefit, disposal).

*) The documents can be downloaded from <http://siemens.com/bt/download>.

Eco design and labeling directives			
ErP class 4	Based on EU Regulation 813/2013 (Eco design directive) and 811/2013 (Labelling directive) concerning space heaters, combination heaters, the following classes apply:		
	Application with On/Off operation of a heater	Class I	Value 1%
	PWM (TPI) room thermostat, for use with On/Off output heaters	Class IV	Value 2%

General data

General		
Dimension	See <i>Dimensions</i>	
Weight	Thermostat with package, user document and accessory	534 g
	Thermostat	219 g
Color	Silver plating Housing: Pantone black	

Diagrams

Connection terminals

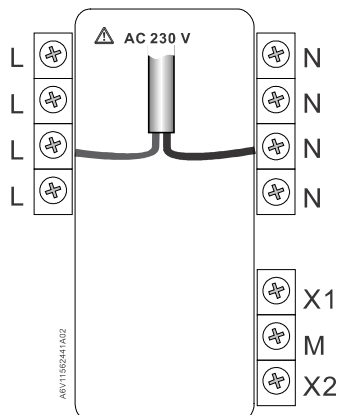

NOTICE! External loads on L and N are not allowed.

Terminal	Use
L, N	Operating voltage AC 230 V
X1, X2, M	Multifunctional inputs

Wiring diagrams

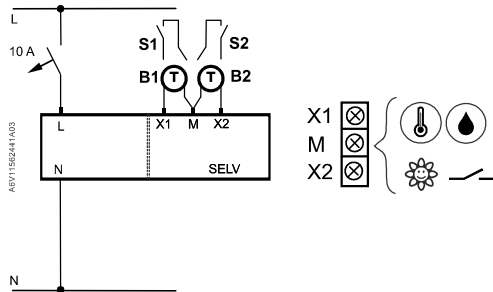

L, N Operating voltage AC 230 V

X1, X2, M Multifunctional inputs

B1, B2 External sensors

S1, S2 External switches

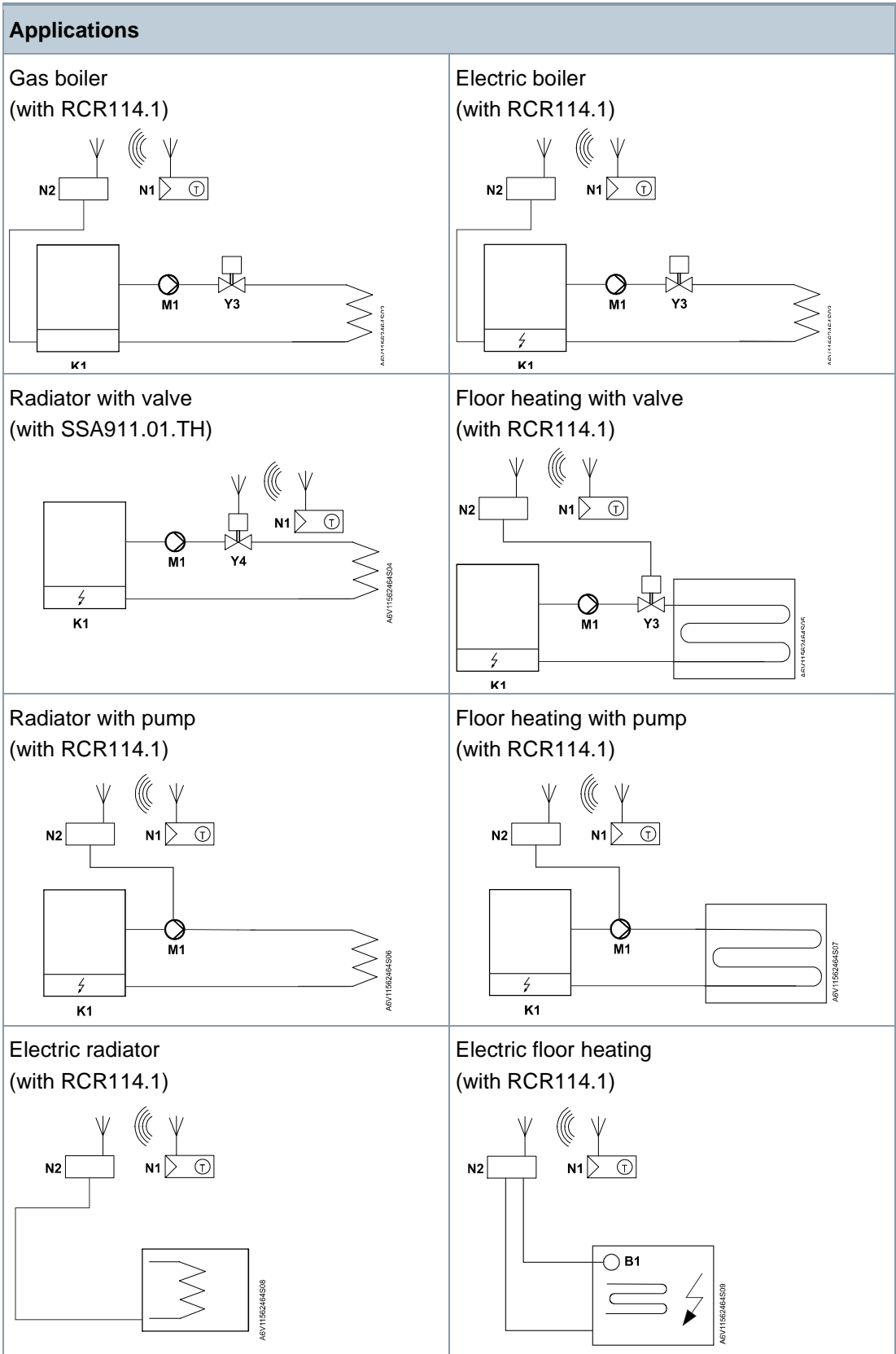

Applications

Fan with electric heating
(with RCR114.1)

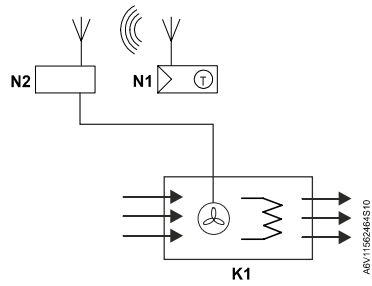

Domestic hot water boiler
(with RCR114.1)

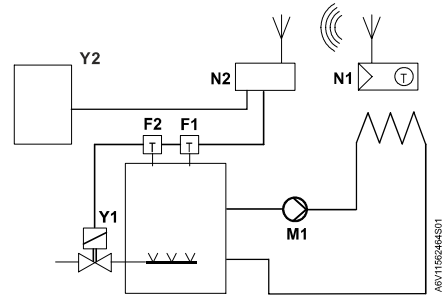

N1	RDS110.R
N2	RCR114.1
F1, F2	Limit thermostats
K1	Heat generator (example, boiler)
Y1	Magnetic valve
Y2	Domestic hot water boiler
Y3	Valve
Y4	SSA911.01TH
M1	Circulating pump

Dimensions

RDS110.R

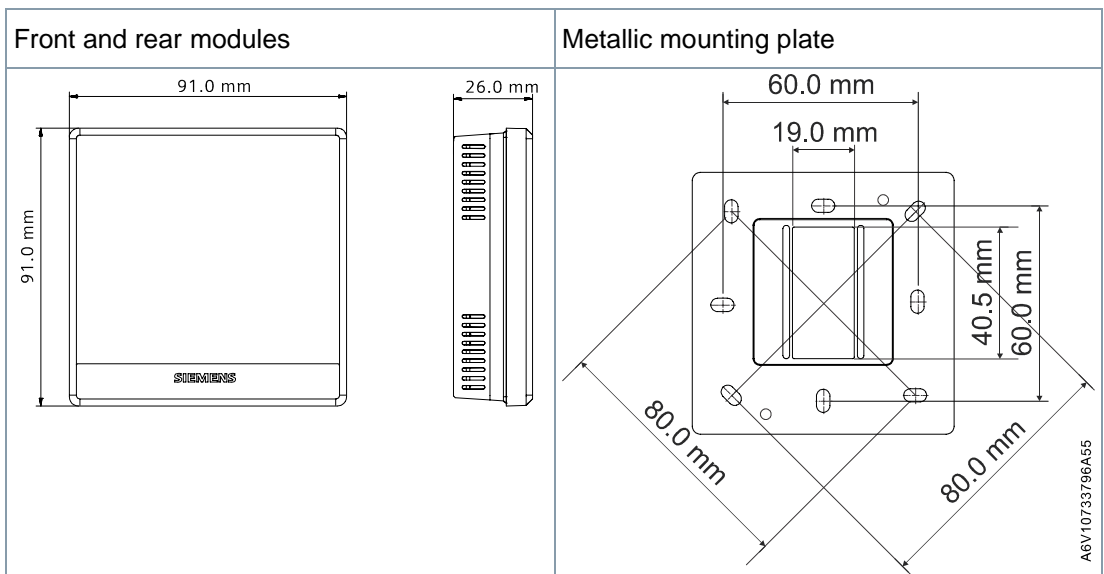

ARG100.01

White decorative frame

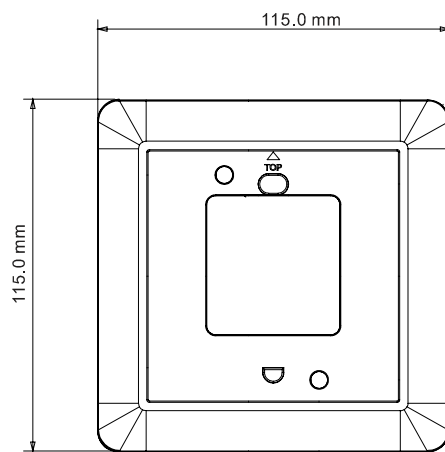

Metallic mounting plate

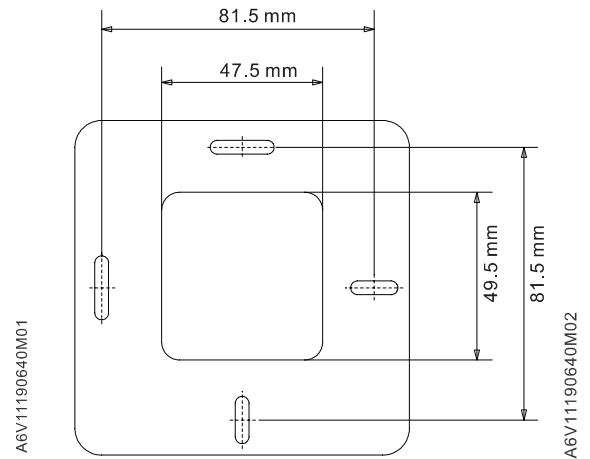

Revision history

Edition	Date	Software version	Changes	Section	Pages
2	July 2021	45.4.46	Removed information about window contact.	Installation	10
1	September 2019	45.4.44	New document	---	---

Issued by
Siemens Switzerland Ltd
Smart Infrastructure
Global Headquarters
Theilerstrasse 1a
CH-6300 Zug
+41 58 724 2424
www.siemens.com/buildingtechnologies

© Siemens Switzerland Ltd, 2021
Technical specifications and availability subject to change without notice.

Document ID A6V11562461_en--_b
Edition 2021-07-16